

MANUAL FOR PHOTOELECTRONIC SMOKE DETECTOR

PRODUCT INTRODUCTION

This product named Photoelectric detector(hereinafter called detector) detects the smoke by a couple of infrared diodes. The principle of detecting is granule in the smoke can reflect infrared light. Infrared diodes are placed in the special chamber. The chamber can shield external light, but don't affect the smoke into it. While have no smoke, the diode can receive very weak infrared light. When the smoke entering the chamber, diode can receive more and more light, when the smoke attains the certain density, the detector can give out alarm signal. In order to reduce the interference and lower power consumption, the emitting circuit adopts the pulse signal. The detector adopts the special structure design and ASIC, has the dustproof, mothproof and anti outside light interference feature etc. The detector is suitable for detect the smoke in house, shop, hotel, restaurant, office building, school, bank, library, computer house and storehouse etc.

PRODUCT PROFILE

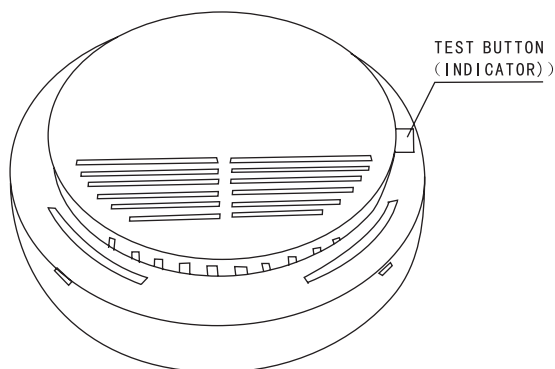

PRODUCT FEATURE

- TEST BY HAND
- AUTO RESET
- ASIC ADOPTED
- ANTI-LIGHT , MOTHPROOF , DUSTPROOF
- STRONG ADAPTABILITY FOR CIRCUMSTANCE
- SMT DESIGN, HIGH STABILITY

TECHNICAL SPECIFICATION

OPERATING VOLTAGE : DC 12V (network type)

9V BATTERY (independence or wireless type)

STATIC CURRENT : $\leq 200\mu\text{A}$ (network type)

$\leq 10\mu\text{A}$ (independence or wireless type)

ALARM CURRENT : $\leq 20\text{mA}$

ALARM INDICATION: RED LED FLASH

SOUND LEVEL: $\geq 85\text{dB/m}$ (independence or wireless type)

OPERATING TEMPERATURE: $-10\text{ }^{\circ}\text{C} \sim +50\text{ }^{\circ}\text{C}$

OPERATING HUMIDITY : $\leq 95\%$ RH

DETECTING AREA: 20 square meter

ALARM OUTPUT : sound & flash alarm (independence type)

RF signal 315MHz or 433MHz (wireless type)

Relay output NO/NC (network type)

RADIO DISTANCE: 100m(open area, wireless type)

SIZE : 107 mm dia.*35mm deep

EXECUTE CRITERION : GB4715-1993

INSTALLATION AND TEST

1. (independence or wireless type) Taking the battery into battery box before installation.
2. (network type) Connect DC 12V power, red wire for anode, black for cathode, white for COM, orange for NO, yellow for NC.
3. Connect the power, the detector comes into operating state. Indicating LED flashes once per 40 seconds, once per 1 second at alarm state.
4. Select proper place (normally mounted on the center of the ceiling), fix the mounting base, then put the detector into the base and turn it.
5. After installation, press the test button to test the output of the detector. LED should flash once per 1s. The detector should give out sound (independence type), should send out RF signal (wireless type), should drive relay (network type).
6. You can press the test button to test the detector or blow a little of smoke into the detector to test if it work properly. The detector will recover to normal working state when the smoke disperse.

NOTICE

1. The detector can not be installed under worse environment. E.g. coldest, hottest, dusty.
2. Please test it monthly.
3. Please clean the detector by soft brush per six monthes to ensure the sensitivity and life of product. Pay attention to switch off power before clean.
4. When the voltage of battery is low or the chamber is dirty, the detector will beep once per 40s. Please change the battery at this condition.(independence or wireless type)
5. For various reason, including, but not limited to changes in environmental conditions, electric disruptions and tampering, the product may not perform as expected. The user is advised to take all necessary precautions for his/her safety and the protection of his/her property.